



240VAC Three Phase Transient Voltage Filters

TFD

Specifications

Electrical

Input Voltage:

up to 240VAC, 3Ø Max.

Frequency:

50/60 Hz

Resistor: 7 watts

Bleeding Resistor: 1 megohms, 1/2 watt

Power Consumption: 37 watts @ 600VAC

Physical

Mounting: Din Rail or Surface

Termination: Terminal Block or

#16 Stranded Wire Leads

Packaging: Dust Cover

Weight: 12 Oz.

Ambient Temperatures

Operating: -40°C to 85°C

Storage: -40°C to 85°C



Ordering Information

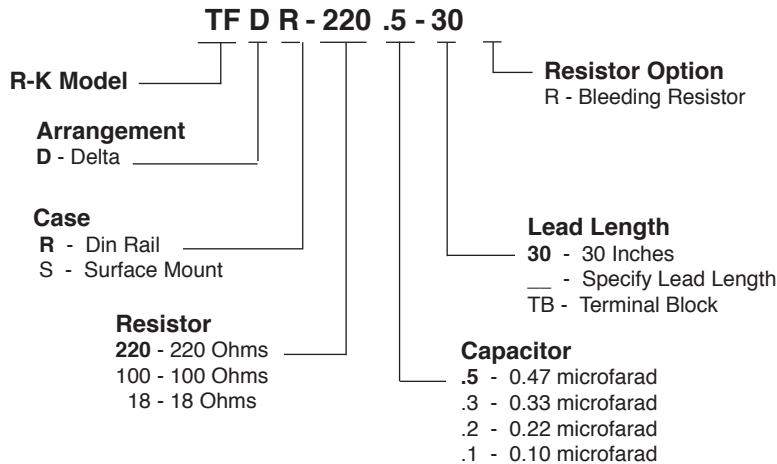

Dimensions

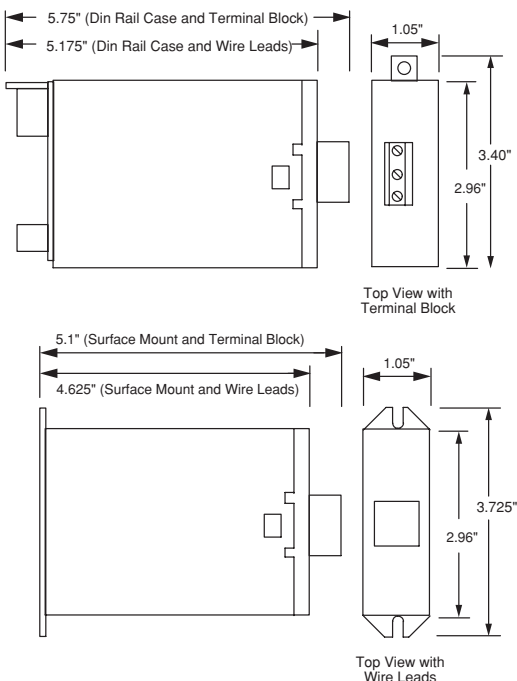

Connections

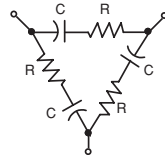

TFD - - -

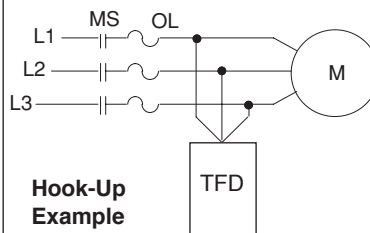

Hook-Up Example

M = Motor
MS = Motor Starter
OL = Overloads

- Din Rail or Surface Mounting
- 240 Volt UL Type Approval
- Delta Configuration
- Three Phase (3Ø) Applications
- Bleeding Resistor Option
- Terminal Block or Leads



E71902
STANDARD 508

Operation

Transient Voltage Filters

TVFs are applied to circuits where transient electrical voltage spikes can cause a malfunction or damage in solid state controls or control systems (PLCs, CNCs, NCs, Solid State Counters, etc.). The TFD is typically applied in parallel with three phase inductive loads (motors) to absorb the transients generated when the load is disconnected from the line. It also absorbs electrical noise while the load is operating. The Bleeding Resistor allows the voltage that builds up on the capacitor in the TFD to bleed off after voltage is removed. The Bleeding Resistor is typically used in applications where the control with the TFD may be operated (tested) without the load (motor) connected.